



**4KHDR**

**HDCP2.2**

**HDBT<sup>ASE</sup>**

**AVLC**



# MA-421

**4x2+1 HDMI Input & HDBaseT/HDMI Output Matrix and  
Amplifier with AVLC, 4KHDR**

**OPERATION MANUAL**



## **DISCLAIMERS**

The information in this manual has been carefully checked and is believed to be accurate. CYP (UK) Ltd assumes no responsibility for any infringements of patents or other rights of third parties which may result from its use.

CYP (UK) Ltd assumes no responsibility for any inaccuracies that may be contained in this document. CYP (UK) Ltd also makes no commitment to update or to keep current the information contained in this document.

CYP (UK) Ltd reserves the right to make improvements to this document and/or product at any time and without notice.

## **COPYRIGHT NOTICE**

No part of this document may be reproduced, transmitted, transcribed, stored in a retrieval system, or any of its part translated into any language or computer file, in any form or by any means—electronic, mechanical, magnetic, optical, chemical, manual, or otherwise—without express written permission and consent from CYP (UK) Ltd.

© Copyright 2011 by CYP (UK) Ltd.

All Rights Reserved.

Version 1.1 August 2011

## **TRADEMARK ACKNOWLEDGMENTS**

All products or service names mentioned in this document may be trademarks of the companies with which they are associated.

## SAFETY PRECAUTIONS

Please read all instructions before attempting to unpack, install or operate this equipment and before connecting the power supply.

Please keep the following in mind as you unpack and install this equipment:

- Always follow basic safety precautions to reduce the risk of fire, electrical shock and injury to persons.
- To prevent fire or shock hazard, do not expose the unit to rain, moisture or install this product near water.
- Never spill liquid of any kind on or into this product.
- Never push an object of any kind into this product through any openings or empty slots in the unit, as you may damage parts inside the unit.
- Do not attach the power supply cabling to building surfaces.
- Use only the supplied power supply unit (PSU). Do not use the PSU if it is damaged.
- Do not allow anything to rest on the power cabling or allow any weight to be placed upon it or any person walk on it.
- To protect the unit from overheating, do not block any vents or openings in the unit housing that provide ventilation and allow for sufficient space for air to circulate around the unit.

## REVISION HISTORY

VERSION NO.	DATE	SUMMARY OF CHANGE
v1.00	08/02/2019	First release
v1.01	12/02/2019	Added Sections 6.3, 6.4, 6.7, 6.8, 8.2; updated Sections 6.6, 8.2

# CONTENTS

<b>1. Introduction</b>	<b>6</b>
<b>2. Applications</b>	<b>7</b>
<b>3. Package Contents</b>	<b>7</b>
<b>4. System Requirements</b>	<b>7</b>
<b>5. Features</b>	<b>8</b>
<b>6. Operation Controls and Functions</b>	<b>9</b>
6.1 Matrix Front Panel	9
6.2 Matrix Rear Panel	10
6.3 Receiver Front Panel	11
6.4 Receiver Rear Panel	12
6.5 Remote Control	13
6.6 IR Cable Pinouts	17
6.7 RS-232 Bypass Pinout	17
6.8 Serial Control	17
6.9 WebGUI Control	18
6.10 Mobile Device App	37
6.11 Telnet Control	43
6.12 RS-232 and Telnet Commands	44
<b>7. Connection Diagram</b>	<b>70</b>
<b>8. Specifications</b>	<b>71</b>
8.1 Technical Specifications -Matrix	71
8.2 Technical Specifications - Receiver	72
8.2 Video Specifications	73
8.3 Audio Specifications	75
8.5 HDBaseT Features	76
<b>9. Acronyms</b>	<b>77</b>

## 1. INTRODUCTION

This 4x2 HDMI to HDBaseT/HDMI Matrix with Stereo Amplifier provides high performance audio and video support, including HDR and ARC, making it ideally suited for multi-zone residential or corporate installations. Any of four high-bandwidth (18Gbps) HDMI sources may be routed to either of the two HDBaseT Zone outputs via a single Cat.5e/6/7 cable (up to 70m at 1080p or up to 35m at 4K) with Zone A's output also being mirrored to a local HDMI output. Despite HDBaseT's 10.2Gbps bandwidth limitation, 4K UHD HDMI video sources, up to and including 4K@60Hz (4:4:4, 8-bit) as well as 10/12-bit sources with HDR, are able to be processed and extended by the use of AVLC (Adaptive Visually Lossless Compression) when connected to compatible AVLC Receivers providing gorgeous video quality.

Pass-through of multiple digital audio formats such as LPCM 7.1, Bitstream and advanced HD Bitstream with audio sampling rates up to 192kHz are supported via the HDBaseT and HDMI outputs. Additionally, the integrated stereo amplifier provides up to 40 watts of power (20W per channel) for local speakers to output the audio from the sources routed to either of the HDBaseT outputs, or from the ARC audio coming back from the display connected to the HDMI output, offering a flexible sound experience (LPCM 2.0 sources only).

This unit also contains a specialised IR learning and smart-routing functionality. IR codes from each connected source's remote can be learned and then recalled using this unit's dedicated remote control, or the mobile device app. Intelligent IR routing ensures that only the IR signals appropriate to the source being viewed in the current zone are used by the dedicated remote control while the mobile device app provides the ability to send IR commands to control any connected source. IR command sets may also be uploaded or downloaded to/from the unit via XML files.

The 48V PoH (Power over HDBaseT) function can provide power to compatible Receivers, providing greater flexibility in installations. This unit can be controlled in a wide variety of different ways including front panel buttons, RS-232, IR remote, Telnet, WebGUI and a mobile device app.

## 2. APPLICATIONS

- /// Conference room installation
- /// Multi-zone home theatre
- /// Meeting room connection
- /// Classroom display

## 3. PACKAGE CONTENTS

- /// 1×HDMI to HDBaseT/HDMI Matrix with Stereo Amplifier
- /// 1×HDMI over HDBaseT Receiver
- /// 1×24V/2.7A DC Power Adapter
- /// 2×Power Cord
- /// 2×2-pin Terminal Block
- /// 5×3.5mm to IR Blaster Cable
- /// 1×Remote Control (CR-186)
- /// 1×Operation Manual

## 4. SYSTEM REQUIREMENTS

- /// HDMI source equipment such as media players, video game consoles or set-top boxes.
- /// HDMI receiving equipment such as HDTVs, monitors or audio amplifiers.
- /// The use of compatible HDBaseT receivers with 48V PoH and AVLC support is recommended.
- /// An active network connection from a switch or router is required for control of the unit via the mobile device app.
- /// The use of industry standard Cat.6, Cat.6a or Cat.7 cable is highly recommended.
- /// HDMI cable distance can be impacted by the materials and design of the cable used. The use of "Premium High Speed HDMI" cables is highly recommended.

## 5. FEATURES

- /// HDMI with HDR, 3D & 4K@60Hz support, DVI 1.0 compatible
- /// HDCP 2.2 and HDCP 1.x compliant
- /// Routes four HDMI sources to two HDBaseT outputs with a mirrored HDMI output with support for automatic input switching
- /// Supports up to 4K UHD (18Gbps, 4K@50/60Hz 4:4:4, 8-bit) video input and output

*Note: Support of resolutions with bandwidth above 10.2Gbps via HDBaseT requires a compatible AVLC Receiver.*

- /// Supports 'Deep Colour' input and output up to 12-bit
- /// Supports 10-bit and 12-bit HDR (High Dynamic Range) input/output
- /// HDBaseT feature support: HD Video and Audio, 48V PoH and Control (bi-directional IR pass-through)
- /// Supports standard 48V PoH from the unit to connected HDBaseT Receivers (compatible Receivers only)
- /// HDBaseT outputs provide simultaneous transmission of uncompressed video, audio and data over a single Cat.5e/6/7 cable up to 70m/230ft at 1080p and 35m/115ft at 4K
- /// Integrated AVLC (Adaptive Visually Lossless Compression) activates when the bandwidth requirements of the source are beyond 10.2Gbps (340MHz) allowing for support of sources up to 18Gbps (600MHz) with no loss of visual quality
- /// Per-output, selectable, 4K to 1080p down-scaling/colour space conversion (4:4:4 to 4:2:0)
- /// Supports pass-through of LPCM 7.1, Bitstream and advanced HD Bitstream audio formats
- /// Supports the Audio Return Channel (ARC) function to transmit digital audio from an ARC-enabled TV connected to the HDMI output (LPCM 2.0 only)
- /// Selectable stereo analogue audio breakout mirrored to both amplified (20W per channel) and un-amplified (3.5mm headphone) connections. (LPCM 2.0 only)
- /// Support for learning IR remote codes for on-demand retransmission
- /// Advanced EDID management with 8 Internal, 3 external EDIDs copied from connected devices, and 4 custom user provided EDIDs
- /// Controllable via front panel buttons, RS-232, IR remote, Telnet, WebGUI and a mobile device app



## 6. OPERATION CONTROLS AND FUNCTIONS

### 6.1 Matrix Front Panel

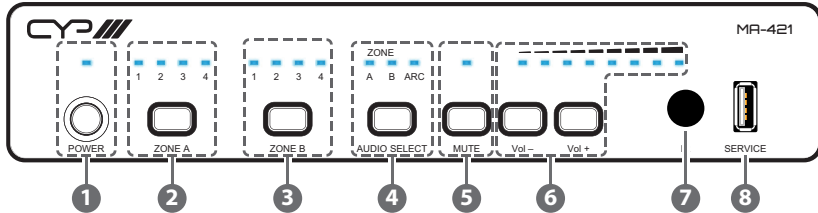

- 1 POWER Button and LED:** Press this button to power the unit on (green LED) or place it into standby mode (red LED).

*Note: If the IR Auto Power Control function is turned on for any inputs/ outputs, this button will also turn on/off those devices that have IR commands stored.*

- 2 ZONE A Button and LEDs:** Press this button to sequentially switch through the available inputs for Zone A. The LED will illuminate to indicate which source is currently selected.

*Note: The selected input will also be displayed on the mirrored HDMI output.*

- 3 ZONE B Button and LEDs:** Press this button to sequentially switch through the available inputs for Zone B. The LED will illuminate to indicate which source is currently selected.

- 4 AUDIO SELECT Button and LEDs:** Press this button to sequentially switch through the available audio sources for both analogue outputs. The LED will illuminate to indicate which source is currently selected. The available sources are: Zone A's current input, Zone B's current input, ARC audio from the HDMI output.

*Note: If the display connected to the HDMI output does not support ARC, no audio will be heard when the ARC source is selected.*

- 5 MUTE Button and LED:** Press to toggle between muting and unmuting the analogue audio output. The LED will illuminate when mute is active.

*Note: By default, the mute button only controls the amplified output. This behavior can be adjusted via RS-232.*

- 6 **VOL-/VOL+ Buttons and LEDs:** Press or hold the +/- (plus/minus) buttons to increase or decrease the amplified analogue audio output volume. The LEDs will illuminate progressively to indicate the current volume level.
- 7 **IR Window:** Accepts IR signals from the included IR remote for control of this unit, IR bypass, and to activate the transmission of learned IR codes.
- 8 **SERVICE Port:** This port is reserved for firmware update use only.

## 6.2 Matrix Rear Panel

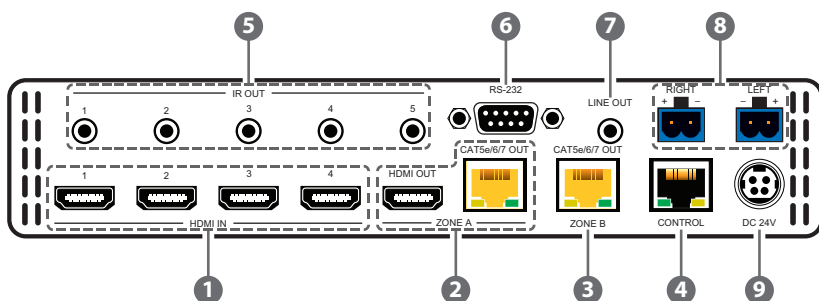

- 1 **HDMI IN 1~4 Ports:** Connect to HDMI source equipment such as media players, game consoles or set-top boxes.
- 2 **ZONE A CAT5e/6/7 & HDMI Ports:**
  - CAT5e/6/7 OUT:** Connect to a compatible HDBaseT Receiver with a single Cat.5e/6/7 cable for transmission of all data signals. 48V PoH will also be supplied to a connected compatible PD Receiver.
  - HDMI OUT:** Connect to an HDMI TV, monitor or amplifier for digital video and audio output.
- 3 **ZONE B CAT5e/6/7 Port:** Connect to a compatible HDBaseT Receiver with a single Cat.5e/6/7 cable for transmission of all data signals. 48V PoH will also be supplied to a connected compatible PD Receiver.
- 4 **CONTROL Port:** Connect to the local network through a network switch or router to control the unit via Telnet, WebGUI, or mobile device app.
- 5 **IR OUT 1~5 Ports:** Connect to the provided IR Blasters to transmit IR signals to devices within direct line-of-sight of the IR Blasters.

- 6 **RS-232 Port:** Connect directly to a PC, laptop or other serial control device to send RS-232 commands to control the unit.
- 7 **LINE OUT Port:** Connect to powered speakers, headphones, or an amplifier for stereo analogue audio output.
- 8 **RIGHT/LEFT Ports:** Connect to unpowered 4Ω speakers for stereo analogue audio output. Up to 20W of power is provided to each speaker channel.
- 9 **DC 24V Port:** Plug the 24V DC power adapter into this port and connect it to an AC wall outlet for power.

### 6.3 Receiver Front Panel

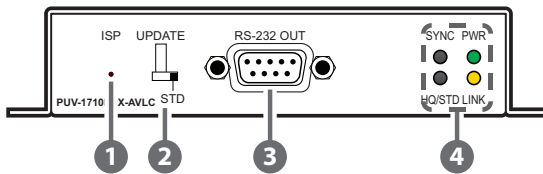

- 1 **ISP:** This button is reserved for factory use only.
- 2 **STD/UPDATE:** This switch is reserved for factory use only. The default setting is “STD”.
- 3 **RS-232 OUT:** Connect to a serial controllable device for the extension of RS-232 signals.
- 4 **SYNC LED:** This LED will illuminate when a live input source is detected.

**HQ/STD LED:** This LED will illuminate whenever the AVLC function is active. A green LED indicates that AVLC is in HQ (High Quality) mode. A red LED indicates that AVLC is in STD (Standard) mode.

**POWER LED:** This LED will illuminate to indicate the unit is on and receiving power.

**LINK LED:** This LED will illuminate solidly when a live connection with a compatible Receiver is active. The LED will blink with a regular pattern if a Receiver is connected but there is not currently a live signal. The LED will blink with an irregular pattern if a connection error has occurred.

## 6.4 Receiver Rear Panel

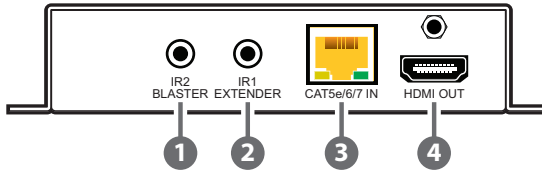

- 1 IR2 BLASTER:** Connect to the provided IR Blaster to transmit IR signals to devices within direct line-of-sight of the IR Blaster.
- 2 IR1 EXTENDER:** Connect to the provided IR Extender to extend the IR control range of remotely located devices. Ensure that the remote being used is within direct line-of-sight of the IR Extender.
- 3 CAT5e/6/7:** Connect to a compatible HDBaseT Transmitter with a single Cat.5e/6/7 cable for transmission of all data signals.
- 4 HDMI OUT:** Connect to an HDMI TV, monitor or amplifier for digital video and audio output.

## 6.5 Remote Control

### 6.5.1 IR Remote (Unit Control)

This unit's IR remote provides control over the unit directly, as well as control over additional external devices through the assignment of learned IR commands.

The following buttons, in "Standard" mode provide direct control over the unit itself. Switching to "Advanced" mode allows these buttons to also be used to control external device functions.

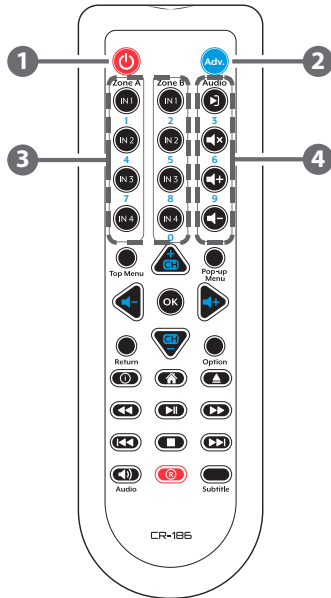

- 1 POWER Button:** Press and hold this button for over 3 seconds to power the unit on or place it into standby mode.

*Note: A short press of this button will send a user defined IR command to the current source device.*

- 2 ADV. Button:** Pressing this button toggles the unit between using the "Standard" and "Advanced" IR remote button definitions.
- 3 ZONE A & ZONE B IN 1~4 Buttons:** Press any of these buttons to switch immediately to the corresponding input for display in Zone A or Zone B respectively.
- 4 AUDIO Buttons**

**SOURCE Button:** Press this button to sequentially switch through the available audio sources for both analogue outputs.

**MUTE Button:** Press to toggle between muting and unmuting the analogue audio output.

*Note: By default, the mute button only controls the amplified output. This behavior can be adjusted via RS-232.*

**VOL+/VOL– Buttons:** Press these buttons to increase or decrease the amplified analogue audio output volume.

## 6.5.2 IR Remote (Assignable Buttons)

### Standard Mode

The function of the buttons on the bottom half of the IR remote are user defined within the WebGUI. They are used to tell the unit to transmit IR commands to the source device currently being viewed in the user's current Zone location.

For example, if the user is watching Input 3 while in Zone A, then pressing any of these buttons will send the associated user-defined commands to the device connected to Input 3 via the IR Blaster connected to IR Output 3. If the user then moves to Zone B, which is watching Input 2, and presses the same buttons, the unit will send commands associated with Input 2 via the IR Blaster connected to IR Output 2.

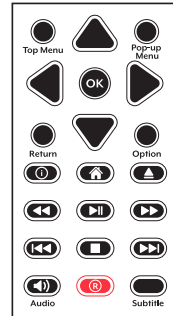

### 1) Zone A Mirrored Outputs (HDBaseT)

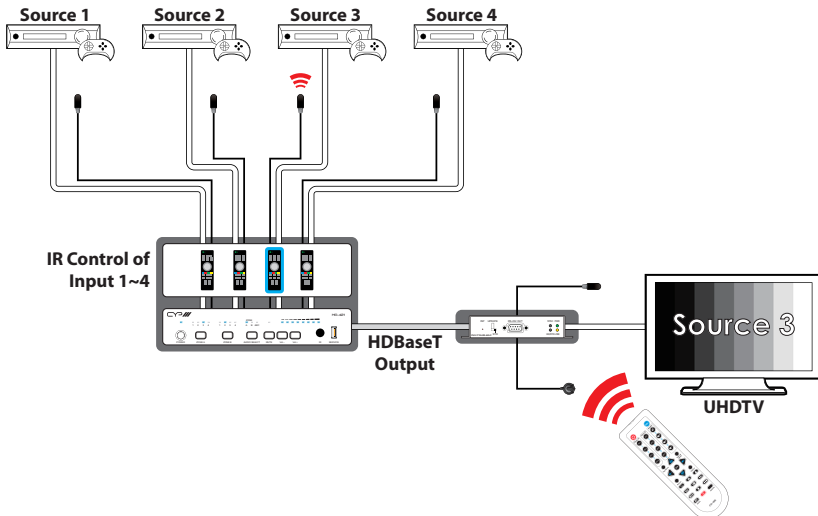

## 2) Zone A Mirrored Outputs (HDMI)

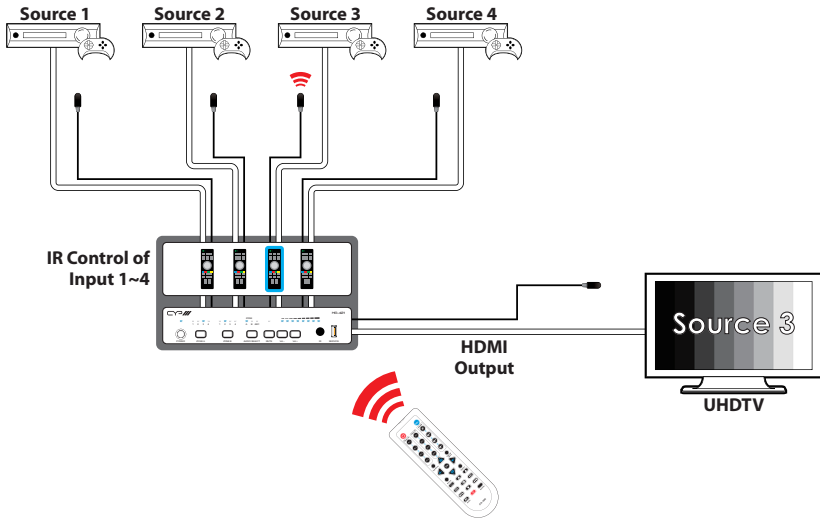

## 3) Zone B Output (HDBaseT)

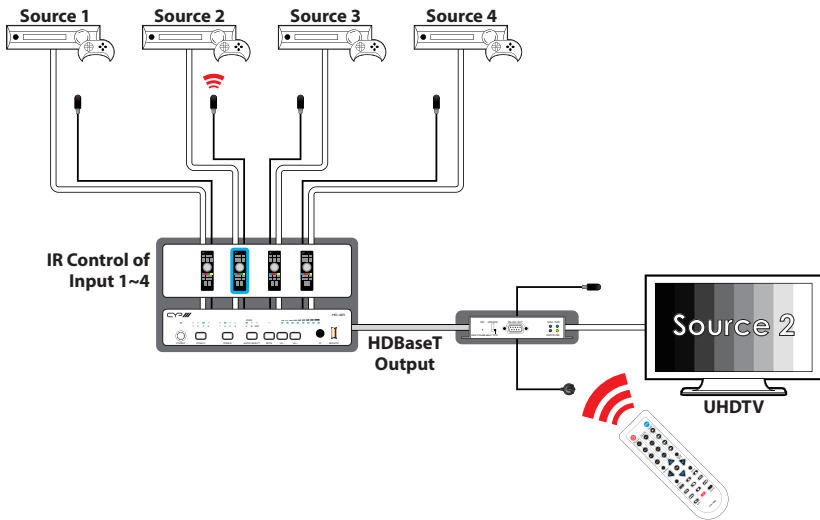

### Advanced Mode

If the “Adv.” button is pressed, the unit will switch into the “Advanced” IR command mode, changing the functionality of these buttons to use additional IR commands that have been defined by the user within the WebGUI. Similar to the other user defined buttons, they are used to tell the unit to transmit IR commands to the source device currently being viewed in the user’s current Zone location. Buttons that have Advanced mode functionality are easily identified by their alternative coloring.

*Note: For detailed information about assigning user defined IR commands within the WebGUI, please refer to Section 6.9.5.*

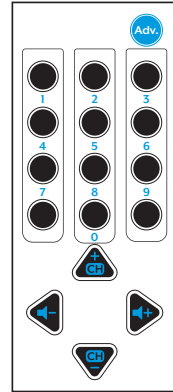



## 6.6 IR Cable Pinouts

IR Blaster Cable

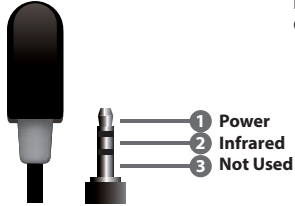

IR Extender Cable

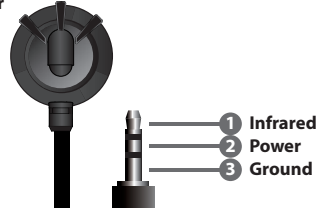

## 6.7 RS-232 Bypass Pinout

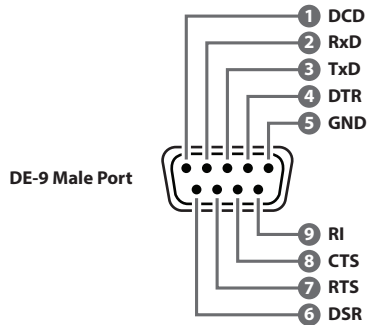
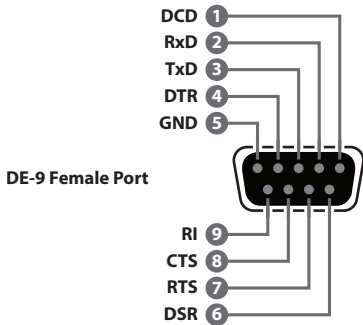

## 6.8 Serial Control

Serial Port Default Settings	
<b>Baud Rate</b>	19200
<b>Data Bits</b>	8
<b>Parity Bits</b>	None
<b>Stop Bits</b>	1
<b>Flow Control</b>	None

## 6.9 WebGUI Control

### Device Discovery

Please obtain the “Device Discovery” software from your authorised dealer and save it in a directory where you can easily find it.

Connect the unit and your PC/Laptop to the same active network and execute the “Device Discovery” software. Click on “Find Devices on Network” and a list of devices connected to the local network will show up indicating their current IP address.

Product Name	Description	IP Address	MAC Address

By clicking on one of the listed devices you will be presented with the network details of that particular device.

Product ID  
 Product Name  
 MAC Address 00:00:00:00:00:00  
 IP Address  
 Subnet Mask  
 Gateway IP  
 DNS  
 IP Mode Static  
 Web GUI Port Static  
 Telnet Port 0  
 S / N  
 Firmware Version  
 Hardware Version  
 Description  
 Web GUI [Web GUI](#)  
 Save Reboot

- 1) IP Mode:** If you choose, you can alter the static IP network settings for the device, or switch the unit into DHCP mode to automatically obtain proper network settings from a local DHCP server. To switch to DHCP mode, please select DHCP from the IP mode drop-down, then click “Save” followed by “Reboot”.
- 2) WebGUI Hotkey:** Once you are satisfied with the network settings, you may use them to connect via Telnet or WebGUI. The network information window provides a convenient link to launch the WebGUI directly.

## WebGUI Overview

After connecting to the WebGUI's address in a web browser, the login screen will appear. Please enter the appropriate user name and password then click "Enter" to log in.

*Note: The default user name and password is "admin".*

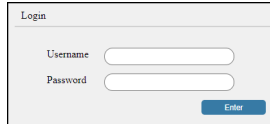

A screenshot of a web browser login page. The page has a light gray background and a white border. At the top left, the word "Login" is displayed. Below it, there are two input fields: "Username" and "Password". To the right of the "Password" field is a blue button with the text "Enter" in white.

On the left side of the browser you will see the following menu tabs where all primary functions of the unit are controllable via the built in WebGUI. The individual functions will be introduced in the following sections.

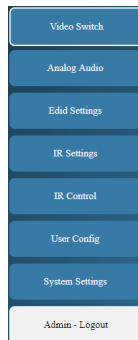

Clicking the "Logout" tab will automatically log the currently connected user out of the WebGUI and return to login page.

### 6.9.1 Video Switch Tab

This tab provides A/V routing control, auto switch controls, and I/O renaming options.

To assign a new A/V route, please click the button of the Zone you wish to send video/audio to on the left and then click on the button of the preferred Input port on the right. Selecting both Zones is possible.

As you select each button they will become outlined in white. The new route will become active immediately and the routing information displayed on the buttons will change accordingly.

*Note: Both outputs included in Zone A (HDBaseT and HDMI) will always show the same source.*



- 1) **Zone A/B:** Buttons for selecting the Output Zone (A or B) to route A/V Inputs to. Details about the Output names and currently selected Input are also displayed here. Clicking on the gear icon (⚙️) opens up the Zone Edit window.
- 2) **Input 1/2/3/4:** Buttons for selecting the HDMI Input (1 through 4) to route to the selected Zone. Details about the Input names and current sync status are also displayed here. Clicking on the gear icon (⚙️) opens up the Input Edit window.

**3) Zone Edit:** Each Zone allows for Individual control over the name of each Output and the behavior of auto switching within that Zone. To edit the settings of a Zone please click the “Edit” icon (⚙️).

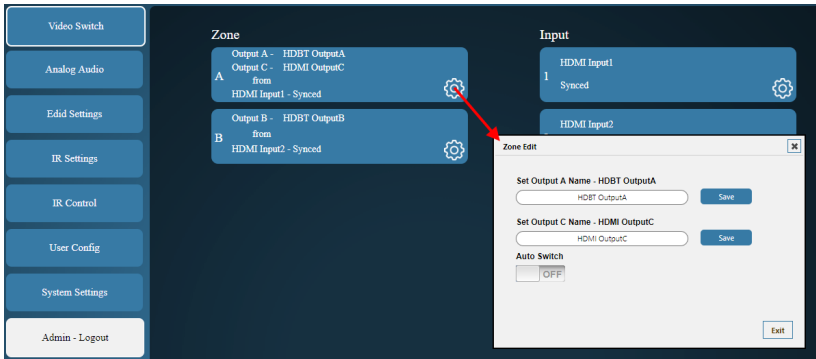

- **Set Output Name:** To rename the Output, type the new name in the space provided in the Edit window. The name can be up to 32 characters long. Click the “Save” button to confirm the change.
- **Auto Switch:** Auto switching may be enabled or disabled individually for each Zone. Click on the On/Off slider to toggle the behavior of the selected Zone.

**4) Input Edit:** Each Input allows for Individual control over its name. To edit the name of an Input please click the “Edit” icon (⚙️) then type the new name in the space provided in the Edit window. The name can be up to 32 characters long. Click the “Save” button to confirm the change.

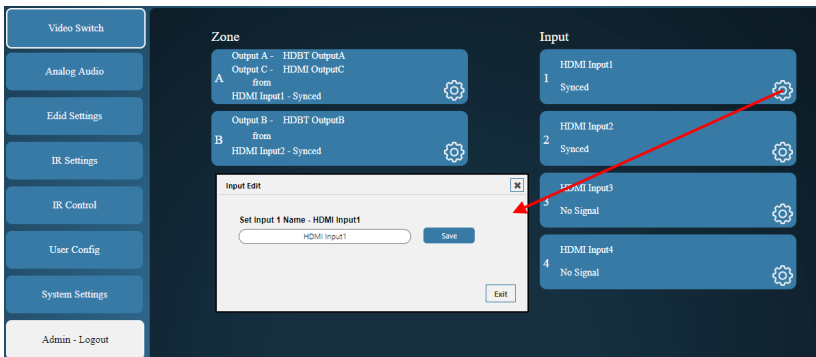

## 6.9.2 Analogue Audio Tab

This tab allows for control over the amplified analogue output of this unit. This unit's DSP allows control over features such as volume, muting, audio delay, equaliser, and L/R balance.

*Note: Only LPCM 2.0 audio sources are supported by the analogue audio output.*



- 1) **Audio Source:** Select the audio source to route to the amplified analogue output from the dropdown.  
*Note: If the display connected to the HDMI output does not support ARC, no audio will be heard when the ARC source is selected.*
- 2) **Audio Position Fix:** Define the location of the amplified analogue speakers, if desired, to restrict the functionality of the front panel "Mute" button, the IR remote's "Audio Source" buttons, and the App's "Audio" controls to only that location. Selecting "Off" allows those  
*Note: Selecting "Zone B" will disable ARC audio as a valid source.*
- 3) **Lip Sync:** Allows the correction of lip sync issues by adjusting the audio delay from 0 to 150ms.

*Note: The maximum amount of delay possible depends on the audio source's sample rate. The value provided here assumes a 48kHz stereo source.*

- 4) **Amplifier:** This unit's amplified output provides a number of controls to fine tune the audio performance of connected analogue speakers.
  - **Mute:** Mute or unmute the amplified analogue output independent of the current line out mute setting.
  - **Equaliser Setting:** Clicking on this button opens up the Equaliser window which has adjustment sliders at a variety of commonly adjusted frequencies from 64Hz to 8kHz. Each slider has an adjustment range of -10 to 10 decibels.
  - **Volume:** Adjusts the volume of the amplified analogue audio output from 0 to 80. Each step is 0.5dB.
  - **Left/Right Enhance:** Allows increasing the volume of the left and right amplified audio outputs independently. Each output can be increased by up to an additional 20dB in 0.5dB steps.
- 5) **Line Out Mute:** Mute or unmute the analogue headphone jack Output independent of the current amplified analogue output mute setting.

### 6.9.3 EDID Settings Tab

This tab provides the option of eight standard EDIDs, three sink sourced EDIDs and four customer uploaded User EDIDs that can be assigned to any or all of the HDMI input ports. Detailed information about any of the EDIDs may also be viewed here.

#### 1) User EDID

- **Upload:** To upload a User EDID, select the User EDID slot to upload into from the dropdown list and then click the “Upload” button. An EDID Upload window will appear, allowing you to locate and upload the preferred EDID file (\*.bin format) from a local PC. Once the correct file has been selected, please click the “Upload” button in the window, and the file will be transferred to the unit.
- **Download:** To save an existing User EDID to your local PC, select the User EDID slot from the dropdown list and then press the “Download” button. Depending on your browser settings you will either be asked where to save the downloaded file, or the file will be transferred to the default download location on your PC.
- **Information:** To view detailed information about a User EDID, select the preferred User EDID slot from the dropdown list and then press the “Information” button.



## 2) Output EDID

- **Download:** To save the EDID from a connected HDMI display to your local PC, select the sink from the dropdown list then press the “Download” button. Depending on your browser settings you will either be asked where to save the downloaded file, or the file will be transferred to the default download location on your PC.
- **Information:** To view detailed information about a connected sink’s EDID, select the preferred sink from the dropdown list and then press the “Information” button.

**3) Input EDID:** Click on one or more input buttons to open the EDID Table List window. Select the new EDID source to use, from the choices on the right, and the change will occur immediately across all selected Inputs.

*Note: In most cases, assigning a new EDID to an input will cause the affected input to briefly blink out while the source adapts to the new information.*

This unit provides the following 8 default EDIDs:

Default EDIDs		
Name	Video Format	Audio Format
<b>FHD/2CH</b>	1920×1080p@60Hz (148MHz) & 8-bit colour	LPCM 2.0
<b>FHD/Multi-CH</b>	1920×1080p@60Hz (148MHz) & 8-bit colour	LPCM 7.1 & Bitstream
<b>UHD/2CH</b>	3840×2160p@30Hz (297MHz) & Deep Colour (8/10/12-bit)	LPCM 2.0
<b>UHD/Multi-CH</b>	3840×2160p@30Hz (297MHz) & Deep Colour (8/10/12-bit)	LPCM 7.1 & Bitstream
<b>UHD+/2CH</b>	3840×2160p@60Hz (594MHz) & Deep Colour (8/10/12-bit)	LPCM 2.0
<b>UHD+/Multi-CH</b>	3840×2160p@60Hz (594MHz) & Deep Colour (8/10/12-bit)	LPCM 7.1 & Bitstream
<b>HDR/2CH</b>	3840×2160p@60Hz (594MHz) & Deep Colour + HDR10	LPCM 2.0
<b>HDR/Multi-CH</b>	3840×2160p@60Hz (594MHz) & Deep Colour + HDR10	LPCM 7.1 & Bitstream

*Note: In some rare cases it is possible for custom or external EDIDs to cause compatibility issues with certain sources. If this happens, it is recommended to switch to one of the 8 default EDIDs for maximum compatibility.*

- **Download:** To save the EDID currently in use by an Input, press the “Download” button next to the preferred Input. Depending on your browser settings you will either be asked where to save the downloaded file, or the file will be transferred to the default download location on your PC.
- **Information:** To view detailed information about an EDID currently in use by an Input, click on the “Information” button next to the preferred Input.

## 6.9.4 IR Settings Tab

This tab provides control over the IR interfaces of the unit and how it interacts with the unit and with devices associated with each input and output.

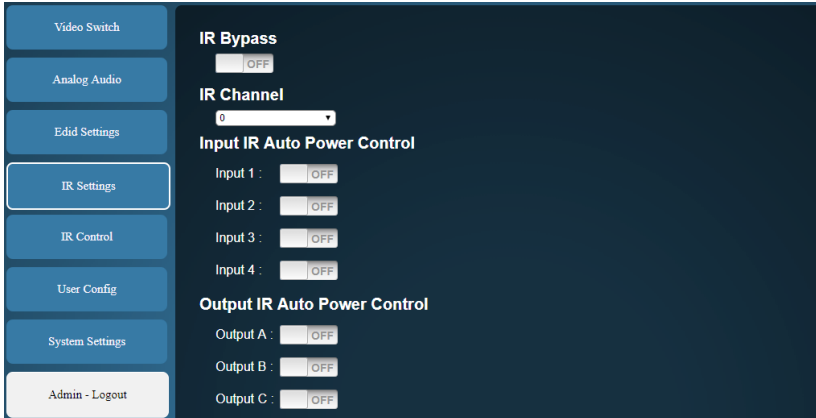

- 1) IR Bypass:** Enable or disable basic IR bypass from connected HDBaseT receivers, or the front IR window, to the Zone's currently selected Input's IR blaster.

*Note: When IR Bypass is enabled, unit-generated IR commands will be delayed by 100ms to avoid conflict with the bypassed IR command.*

- 2) IR Channel:** Sets the IR channel to use with the unit's dedicated IR remote control.

*Note: The IR channel of the unit and the dedicated IR remote control must match in order for the unit to be controlled.*

- 3) Input IR Auto Power Control:** Enable or disable the Auto Power Control for the IR blaster associated with each Input on the unit. When enabled, the unit will transmit the appropriate power button IR command, from the associated Input's IR blaster, any time the unit is powered on or placed into standby mode.

*Note: The device-specific power button IR command must be learned and stored in the unit for each Input. The IR transmission will be delayed by 10 seconds to accommodate warmup requirements of certain devices.*

- 4) **Output IR Auto Power Control:** Enable or disable the Auto Power Control for the IR blaster associated with each Output on the unit. When enabled, the unit will transmit the appropriate power button IR command, from the associated Output's IR blaster, any time the unit is powered on or placed into standby mode.

*Note: The device-specific power button IR command must be learned and stored in the unit for each Input. The IR transmission will be delayed by 10 seconds to accommodate warmup requirements of certain devices.*

## 6.9.5 IR Control Tab

This tab provides control over the handling of all IR commands stored within the unit, including learning commands to be assigned to the buttons on the IR remote/App for each input and output, enabling the Advanced and Extension button sets, renaming each button, as well as saving/loading the IR configuration for each source or sink to/from a PC file. The app's behavior may also be simulated, allowing each button to be tested to ensure the proper IR signal is transmitted.

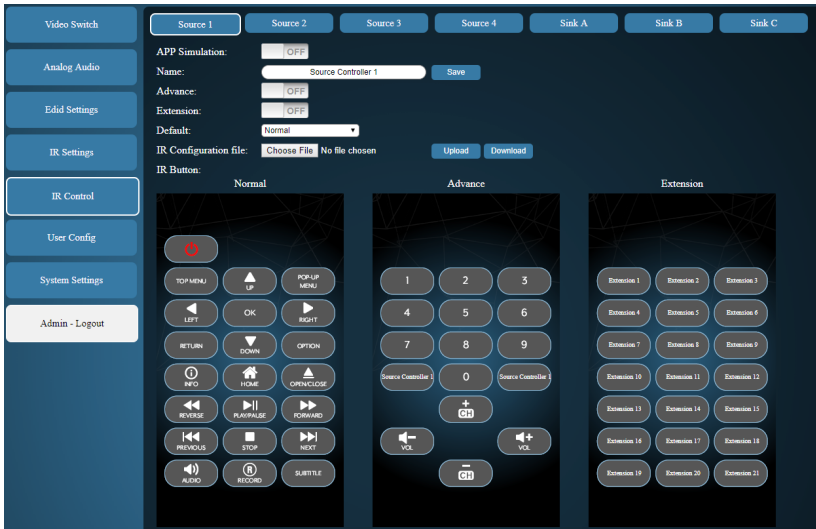

1) **Source 1~4/Sink A~C Buttons:** Press the button of the Source or Sink that you wish to configure the IR commands for.

*Note: All settings below are individually set and stored for each Source or Sink.*

- **APP Simulation:** Enable or disable simulating the app with the buttons below to allow for the convenient testing of learned codes. When enabled, pressing any of the remote buttons on this web page will transmit the IR command defined within that button to the current Source or Sink.
- **Name:** Allows renaming the current Source or Sink's remote for easy identification. Type the new name in the space provided. The name can be up to 32 characters long. Click the "Save" button to confirm the change.

- **Advance:** Enable or disable the availability of the “Advance” IR remote button set for the current Source or Sink.  
*Note: The “Advance” buttons are available on both the IR remote and the app.*
- **Extension:** Enable or disable the availability of the “Extension” IR remote button set for the current Source or Sink.  
*Note: The “Extension” buttons are only available in the app.*
- **Default:** Set the default button set to display when this Source or Sink is selected in the app.
- **IR Configuration file Upload:** Previously saved IR device configurations may be restored from a saved XML file. Click the “Choose File” button to locate the saved XML file, then click the “Restore” button to load the selected configuration.  
*Note: Only the IR command settings for a single Source or Sink are included in the file.*
- **IR Configuration file Download:** The current IR device configuration, including all learned IR commands, may be saved as an XML file to a PC. Click the “Download” button to save the current IR device configuration to your local PC.  
*Note: Only the IR command settings for the currently selected Source or Sink are included in the file.*
- **Normal/Advance/Extension:** Displays all available buttons for each IR Remote mode. Clicking on a button will open up its Command Edit window, allowing an IR command to be learned or manually entered and associated with the button.  
*Note: The “Extension” button set is only available in the app.*

- 2) **Command Edit:** Clicking on any button from the Normal, Advance, or Extension IR button groups will open up its Command Edit window, allowing an IR command to be learned or manually entered and associated with the button. Click the “Save Change” button to confirm and store the current data to the button.

*Note: Only buttons that have IR codes associated with them will be visible in the mobile device app.*

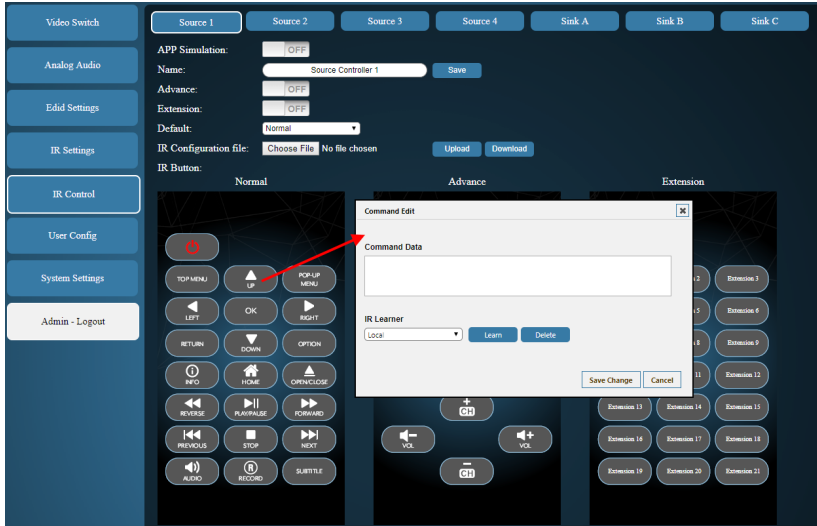

- **Key Name (“Extension” and “Source Controller” buttons only):** Allows renaming the current button for easy identification. Type the new name in the space provided. The name can be up to 32 characters long.

*Note: The custom key name will also appear in the app.*

- **Command Data:** Contains the IR command data to be transmitted when the associated remote button is pressed. This data can be learned from an external remote or manually entered.

- IR Learner:** To learn an IR command from a physical IR remote, select the location of the IR Receiver to learn into from the dropdown (Local, Zone A, Zone B), and then click the “Learn” button. After selecting “Learn”, you have 15 seconds to point the IR remote at the appropriate IR Receiver and press the remote button to learn. After 15 seconds have passed, the learned IR command (if any) will be displayed in the Command Data space. To delete a previously learned IR command, press the “Delete” button.
- 3) **Command Edit (PLAY/PAUSE Button):** Clicking on the PLAY/PAUSE button from the Normal button group opens a special Command Edit window, allowing control over the behavior of the button in addition to assigning an IR command. Some remotes use separate buttons for “Play” and “Pause”. In those cases a second IR command for the “Pause” function may be assigned to this button. Click the “Save Change” button to confirm and store the current data to the button.

- Play Key Command Data:** Contains the IR command data to be transmitted when the PLAY/PAUSE button is pressed. This data can be learned from an external remote or manually entered.

*Note: If separate Play and Pause commands are defined, they will be transmitted alternately with each press of the button.*



- **Play Key IR Learner:** To learn an IR command from a physical IR remote, select the location of the IR Receiver to learn into from the dropdown (Local, Zone A, Zone B), and then click the “Learn” button. After selecting “Learn”, you have 15 seconds to point the IR remote at the appropriate IR Receiver and press the remote button to learn. After 15 seconds have passed, the learned IR command (if any) will be displayed in the Command Data space. To delete a previously learned IR command, press the “Delete” button.
- **Pause Key the same with Play Key:** Enables or disables support for a single-command PLAY/PAUSE button. When enabled, only a single command is stored and transmitted when the PLAY/PAUSE button is pressed. When disabled, pressing the PLAY/PAUSE key will toggle between the Play and Pause IR commands with each press.
- **Pause Key Command Data:** Contains the IR command data to be transmitted when the PLAY/PAUSE button is pressed. This data can be learned from an external remote or manually entered.
- **Pause Key IR Learner:** To learn an IR command from a physical IR remote, select the location of the IR Receiver to learn into from the dropdown (Local, Zone A, Zone B), and then click the “Learn” button. After selecting “Learn”, you have 15 seconds to point the IR remote at the appropriate IR Receiver and press the remote button to learn. After 15 seconds have passed, the learned IR command (if any) will be displayed in the Command Data space. To delete a previously learned IR command, press the “Delete” button.

### 6.9.6 User Config Tab

The WebGUI and Telnet username/password are set on this page. Two management levels are available: “Administrator” and “General User”. The usernames are pre-defined as “admin” and “user” and cannot be changed.

*Note: The “Administrator” user has access to all tabs and can change all settings. The “General User” has certain configuration functions disabled, such as IR Control, device renaming, etc.*

Section	Field	Value
Administrator	Username	admin
	Old Password	
	New Password	
	Confirm New Password	
General User	Username	user
	Old Password	
	New Password	
	Confirm New Password	

## 6.9.7 System Settings Tab

This tab provides system information, power control, network configuration options, system configuration backup/restore/reset, and firmware update functions.

- 1) **Serial Number/Firmware Version:** Displays the unit's serial number and current firmware version.
- 2) **Power:** Provides control over the unit's power state.
  - **Control:** Press this switch to toggle the unit's power between ON and OFF (standby mode).  
*Note: While in standby mode the unit's WebGUI, Telnet and RS-232 controls are still active.*
  - **Auto Standby:** Set the length of time (in minutes) to wait before automatically putting the unit into standby mode if there are no valid input signals detected. Setting this to "0" will disable the feature.
- 3) **Keypad Lock:** Enable or disable the front panel key lock. When enabled, the use of all front panel buttons will be disabled.

- 4) **Network:** IP mode may be switched between Static IP or DHCP. In Static IP mode the IP, netmask and gateway addresses may be manually set. When in DHCP mode, the unit will attempt to connect to a local DHCP server and obtain IP, netmask and gateway addresses automatically. Please press “Save” after making any changes to the IP configuration or mode. To return all network settings to their defaults, press the “Network Reset” button.

*Note: If the IP address is changed then the IP address required for WebGUI/Telnet access will also change accordingly.*

- 5) **Web Timeout:** Select the length of time to wait before logging the user out of the WebGUI due to inactivity. Available range is from 1 to 120 minutes.
- 6) **Download Current Configuration:** The current system configuration, including routing and settings, may be saved as an XML file to a PC. Click the “Download” button to save the current system configuration to your local PC.
- 7) **Restore Configuration:** Previously saved system configurations may be restored from a saved XML file. Click the “Choose File” button to locate the saved XML file, then click the “Restore” button to activate the selected configuration.
- 8) **Reset to Default:** Press the “ALL Reset” button to reset the unit to its factory default state. After the reset is complete, the unit will reboot automatically.
- 9) **Firmware Upgrade:** To update the unit's firmware, click the “Choose File” button to open the file selection window and then select the firmware update file (\*.bin format) located on your local PC. After selecting the file, click the “Upgrade” button to begin the firmware update process. After the upgrade is complete, the unit will reboot automatically.

## 6.10 Mobile Device App

This unit may also be controlled via a dedicated mobile device control application which is available for download. Please contact your authorised dealer for details on how to obtain the app. The app provides flexible control over the unit, going beyond what the physical remote allows. It has a number of important advanced functions including source selection, IR control over both sources and displays, as well as customised button layouts for each controlled device. The app facilitates control over any source or display, that has IR commands assigned to buttons within the WebGUI, regardless of the user's current location.

### Control App Overview

After successfully downloading and installing the Control App, connect the unit and your mobile device to the same active network and start the Control App.

Once the startup screen appears, tap on the Start icon (●) and the app will automatically discover the unit to control and display the main control page.

*Note: If no controllable unit exists on the local network, this app can be operated in a "demo" mode by pressing and holding the Start icon (●) for 5 seconds.*



### 6.10.1 App Main Page

The app's Main page provides access to all of the IR commands available for the currently selected Zone's video source or display as defined within the unit's WebGUI. This page also provides an easy way to switch inputs, change the amplified audio source, and control the amplified audio volume via the bottom Control Slider's row of buttons. Shortcut buttons to refresh the app's data or access the app's Selection Menu are also provided at the top.

*Note: For detailed information about assigning user defined IR commands within the WebGUI, please refer to Section 6.9.5.*



- 1) **Menu Icon (☰):** Pressing this button once will open the “Selection Menu” page. Pressing it again will return to the Main page. The Selection Menu page provides a way to change the current viewing Zone.
- 2) **App Data Refresh Icon (🔄):** Pressing this button will force the app to refresh the IR Remote button layout data from the unit.
- 3) **Zone & Input Identification:** This section at the top of the page identifies which display (Zone A, Zone B, or Output C) and which Input (HDMI 1~4) are currently selected for IR control. The Selection Menu page provides a way to change the current display and the Input can be changed via the bottom slider buttons.

- 4) IR Remote Control Buttons:** Up to three sets of IR control buttons are available for every device (Normal, Advance, Extension). The starting page and which button pages are available for each device is determined by the settings for that device in the unit's WebGUI.

*Note: Only buttons that have IR codes associated with them will be visible.*

### Normal IR Remote Buttons

These buttons share their functions with the buttons at the bottom of the unit's physical remote, as defined within the unit's WebGUI. Pressing any of these buttons will send the defined IR command to the IR Blaster associated with the current Input or local display.



### Advance IR Remote Buttons

These buttons share their functions with the "Advance Mode" buttons on the unit's physical remote, as defined within the unit's WebGUI. To access these buttons in the app, press the "ADV." button. To return to the Normal button set, press the button a second time. Pressing any of these buttons will send the defined IR command to the IR Blaster associated with the current Input or local display.

*Note: If the Advance button set has been disabled in the unit's WebGUI for the current device, this page will not be available.*



## Extension IR Remote Buttons

These buttons are only available within the app and are defined within the unit's WebGUI under the "Extension" set. To access these buttons in the app, press the "EXT." button. To return to the Normal button set, press the button a second time. Pressing any of these buttons will send the defined IR command to the IR Blaster associated with the current Input or local display.

*Note: If the Extension button set has been disabled in the unit's WebGUI for the current device, this page will not be available.*



### 6.10.2 App Unit Control Slider

This slider at the bottom of the app's main page provides an easy way to switch inputs, change the amplified audio source, control the amplified audio volume, or select the local display for IR control. To access the additional buttons on the slider, slide the menu bar to the left or right.

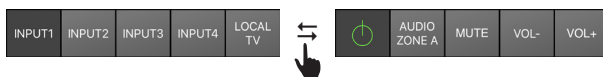

#### 1) Control Slider (Left Set)

- **Input 1~4:** Pressing any of these buttons will switch the current Zone's source to the Input selected. When a new Input is selected, the IR Remote Control buttons available will also change to match the newly selected Input.
- **Local TV:** Pressing this button will show the IR Remote Control buttons that have been defined for the currently selected Zone's display. Press the button a second time to return to showing the current Input's IR Remote Control buttons.

*Note: Selecting Local TV will not change the currently selected Input.*



## 2) Control Slider (Right Set)

- **Power Icon (⏻):** Press this button to turn the unit on or place it into standby mode.
- **Audio Source Selection:** Pressing this button will toggle through the 3 available audio sources for the analogue outputs (Zone A's source, Zone B's source, ARC).

*Note: If the display connected to the HDMI output does not support ARC, no audio will be heard when the ARC source is selected.*

- **Mute:** Press this button to mute or unmute the analogue outputs.
- **Vol-/Vol+:** Press these buttons to increase or decrease the volume level of the amplified audio output.

### 6.10.3 App Zone Selection Page

The Selection Menu page provides a way to select which Zone and Output to display controls for, as well a way to search for other units within the local network. Links to information about the app and other products from the company are also available.

1) **Menu Icon (☰):** Pressing this button will return to the Main page.

#### 2) Zone A

- **HDBT:** Select this to control the display connected to Output A (HDBaseT A) and the currently routed input. After selection, the app will automatically return to the Main page.
- **HDMI:** Select this to control the display connected to Output C (HDMI) and the currently routed input. After selection, the app will automatically return to the Main page.

#### 3) Zone B

- **HDBT:** Select this to control the display connected to Output B (HDBaseT B) and the currently routed input. After selection, the app will automatically return to the Main page.

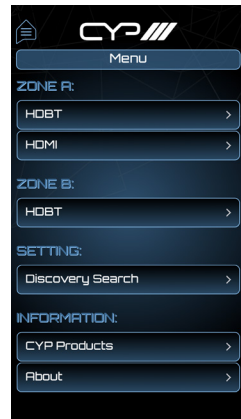

#### 4) Setting

- **Discovery Search:** Select this to search for additional units within the local network. After selecting a new unit, the details from that unit will automatically be loaded into the app.

#### 5) Information

- **CYP Products:** Links to a web page with information about other products available from the company.
- **About:** Displays information about the App version and Unit firmware version.

## 6.11 Telnet Control

Before attempting to use Telnet control, please ensure that both the unit and the PC are connected to the same active networks.

To Access the Command Line Interface (CLI)	
Windows 7	Click <b>Start</b> , type “cmd” in the search field, and press <b>Enter</b> .
Windows XP	Click <b>Start &gt; Run</b> , type “cmd”, and press <b>Enter</b> .
Mac OS X	Click <b>Go &gt; Applications &gt; Utilities &gt; Terminal</b> .

Once in the Command Line Interface (CLI) type “**telnet**” followed by the IP address of the unit (and the port number if it is non-standard) and then hit “**Enter**”. This will connect us to the unit we wish to control.

```
Microsoft Windows [Version 6.1.7601]
Copyright (c) 2009 Microsoft Corporation. All rights reserved.

C:\Users\Administrator>telnet 192.168.1.50 23
```

*Note: If the IP address is changed then the IP address required for Telnet access will also change accordingly.*

## 6.12 RS-232 and Telnet Commands

### 6.12.1 System Commands

COMMAND	
Description and Parameters	
<b>help</b> ↵	Show the full command list.
<b>help N1</b> ↵	Show details about the specified command. <b>N1</b> = {Command}
<b>?</b> ↵	Show the full command list.
<b>? N1</b> ↵	Show details about the specified command. <b>N1</b> = {Command}
<b>get model name</b> ↵	Show the unit's model name.
<b>get fw ver</b> ↵	Show the unit's current firmware version.
<b>set system reboot</b> ↵	Reboot the unit.
<b>set description N1</b> ↵	Set the description/name of the unit. <b>N1</b> = {Name} [64 characters max]
<b>get description</b> ↵	Show the unit's current description/name.

### 6.12.1 System Commands

COMMAND	
Description and Parameters	
<b>set keylock N1</b> ←	
Enable or disable the front panel key lock.	
Available values for <b>N1</b> :	
ON	[Lock front panel]
OFF	[Unlock front panel]
<b>get keylock</b> ←	
Show the current front panel key lock status.	
<b>set power N1</b> ←	
Power the unit on or place it into standby mode.	
Available values for <b>N1</b> :	
ON	[Power on]
OFF	[Standby Mode]
<b>get power</b> ←	
Show the current power status.	
<b>set auto standby timer N1</b> ←	
Set the length of time to wait before placing the unit into standby mode when there is no detected live input.	
Available values for <b>N1</b> :	
0	[Timer disabled]
1 ~ 255	[Minutes]
<b>get auto standby timer</b> ←	
Show the current auto standby timer setting.	
<b>set factory default</b> ←	
Reset all configurations to the factory defaults.	

### 6.12.2 Input Commands

COMMAND
Description and Parameters
<p><b>get in port number</b>↵</p> <p>Report the number of inputs supported by the unit</p>
<p><b>get in type list</b>↵</p> <p>List the interface supported by each input.</p>
<p><b>set in N1 name N2</b>↵</p> <p>Set the name of the specified input.</p> <p><b>N1</b> = 1 ~ 4                   [HDMI Input]</p> <p><b>N2</b> = {Name}                 [32 characters max]</p>
<p><b>get in N1 name</b>↵</p> <p>Show the current name of the specified input.</p> <p><b>N1</b> = 1 ~ 4                   [HDMI Input]</p>
<p><b>set in N1 hdcp mode N2</b>↵</p> <p>Set the HDCP behavior of the specified input.</p> <p><b>N1</b> = 1 ~ 4                   [HDMI Input]</p> <p>Available values for <b>N2</b>:</p> <p>0                                 [Disable HDCP]</p> <p>1                                 [Refer to source]</p> <p>2                                 [Refer to sink]</p>
<p><b>get in N1 hdcp mode</b>↵</p> <p>Show the current HDCP behavior used by the specified input.</p> <p><b>N1</b> = 1 ~ 4                   [HDMI Input]</p>

## 6.12.2 Input Commands

COMMAND	
Description and Parameters	
<b>set in N1 edid N2</b> ↵	
Set the EDID to use on the specified input.	
<b>N1</b> = 1 ~ 4	[HDMI Input]
Available values for <b>N2</b> :	
1	[Internal FHD 2CH]
2	[Internal FHD Multi-CH]
3	[Internal UHD 2CH]
4	[Internal UHD Multi-CH]
5	[Internal UHD+ 2CH]
6	[Internal UHD+ Multi-CH]
7	[Internal HDR 2CH]
8	[Internal HDR Multi-CH]
9	[User EDID1]
10	[User EDID2]
11	[User EDID3]
12	[User EDID4]
13	[Copy Output A]
14	[Copy Output B]
15	[Copy Output C]
<b>get in N1 edid data</b> ↵	
Show the EDID currently used by the specified input as ASCII hex data.	
<b>N1</b> = 1 ~ 4	[HDMI Input]
<b>get in N1 edid information</b> ↵	
Show English readable details from the EDID assigned to the specified input.	
<b>N1</b> = 1 ~ 4	[HDMI Input]

### 6.12.2 Input Commands

COMMAND	
Description and Parameters	
<b>set in N1 power control N2</b> ↵	
<p>Enable or disable the auto power control feature for the specified input.</p> <p><b>N1</b> = 1 ~ 4                      [HDMI Input]</p> <p>Available values for <b>N2</b>:</p> <p>ON                                      [Enable Power Control]</p> <p>OFF                                      [Disable Power Control]</p>	
<b>get in N1 power control</b> ↵	
<p>Show the current state of the auto power control setting for the specified input.</p> <p><b>N1</b> = 1 ~ 4                      [HDMI Input]</p>	



### 6.12.3 Output Commands

COMMAND	
Description and Parameters	
<b>get out port number</b> ↵	
	Show the total number of outputs on the unit.
<b>get out type list</b> ↵	
	List the port type of all outputs on the unit.
<b>set out N1 name N2</b> ↵	
	Set the name of the specified output.
<b>N1</b> = A ~ C	[Output]
<b>N2</b> = {Name}	[32 characters max]
<b>get out N1 name</b> ↵	
	Show the name of the specified output.
<b>N1</b> = A ~ C	[Output]
<b>set out N1 convert N2</b> ↵	
	Set the 4K compatibility conversion behavior used by the specified output.
<b>N1</b> = A ~ C	[Output]
	Available values for <b>N2</b> :
0	[Bypass, no conversion]
1	[Convert the colour space to YUV 4:2:0]
2	[Convert the resolution to 1080p]
3	[Automatic, based on sink EDID]
<b>get out N1 convert</b> ↵	
	Show the current 4K compatibility conversion behavior used by the specified output.
<b>N1</b> = A ~ C	[Output]

### 6.12.3 Output Commands

COMMAND
Description and Parameters
<p><b>get out N1 hpd</b> ←</p> <p>Show the current hot-plug state of the specified output.</p> <p><b>N1</b> = A ~ C                      [Output]</p>
<p><b>get out N1 rsense</b> ←</p> <p>Show the current receiver sense state of the specified output.</p> <p><b>N1</b> = A ~ C                      [Output]</p>
<p><b>get out N1 edid data</b> ←</p> <p>Show the EDID used by the specified output as ASCII hex data.</p> <p><b>N1</b> = A ~ C                      [Output]</p>
<p><b>get out N1 edid information</b> ←</p> <p>Show English readable details from the EDID of the specified output.</p> <p><b>N1</b> = A ~ C                      [Output]</p>
<p><b>set out N1 power control N2</b> ←</p> <p>Enable or disable the auto power control feature for the specified output.</p> <p><b>N1</b> = A ~ C                      [Output]</p> <p>Available values for <b>N2</b>:</p> <p>ON                                      [Enable Power Control]</p> <p>OFF                                     [Disable Power Control]</p>
<p><b>get out N1 power control</b> ←</p> <p>Show the current state of the auto power control setting for the specified input.</p> <p><b>N1</b> = A ~ C                      [Output]</p>

## 6.12.4 Zone Commands

COMMAND	
Description and Parameters	
<b>set zone N1 route N2</b> ↵↵	
Route the specified input to the specified Zone.	
<b>N1</b> = A ~ B	[Output Zone]
<b>N2</b> = 1 ~ 4	[HDMI Input]
<b>get zone N1 route</b> ↵↵	
Show the current input routed to the specified Zone.	
<b>N1</b> = A ~ B	[Output Zone]
<b>set zone N1 auto route N2</b> ↵↵	
Enable or disable the automatic routing function of the specified Zone.	
<b>N1</b> = A ~ B	[Output Zone]
Available values for <b>N2</b> :	
ON	[Auto routing enabled]
OFF	[Auto routing disabled]
<b>get zone N1 auto route</b> ↵↵	
Show the current automatic routing function state for the specified Zone.	
<b>N1</b> = A ~ B	[Output Zone]

### 6.12.5 User EDID Commands

COMMAND	
Description and Parameters	
<b>get user edid number</b> ↵	
	Report the number of user edid supported by the unit.
<b>set user N1 edid data N2</b> ↵	
	Upload a new EDID (in ASCII hex format) for use as the specified User EDID.
<b>N1</b> = 1 ~ 4	[User EDID number]
<b>N2</b> = {Comma delimited hex pairs}	[EDID data]
<b>get user N1 edid data</b> ↵	
	Show the EDID used by the specified User EDID as ASCII hex data.
<b>N1</b> = 1 ~ 4	[User EDID number]
<b>get user N1 edid information</b> ↵	
	Show English readable details from the specified User EDID.
<b>N1</b> = 1 ~ 4	[User EDID number]

## 6.12.6 Analogue Audio Commands

COMMAND	
Description and Parameters	
<b>set analog audio route N1</b> ←	
Route the specified audio source to the analogue audio outputs. Available values for <b>N1</b> :	
A	[Zone A's audio]
B	[Zone B's audio]
C	[HDMI output's ARC audio]
<b>get analog audio route</b> ←	
Show the current analogue audio routing source.	
<b>set analog audio mute purpose N1</b> ←	
Define the functionality of the front panel and remote control's mute buttons. Available values for <b>N1</b> :	
1	[Mutes amplifier only]
2	[Mutes line out only]
3	[Mutes both]
<b>get analog audio mute purpose</b> ←	
Show the current analogue audio mute button functionality setting.	
<b>set amplifier mute N1</b> ←	
Enable or disable muting the amplified audio output. Available values for <b>N1</b> :	
ON	[Muted]
OFF	[Unmuted]
<b>get amplifier mute</b> ←	
Show the current mute state of the amplified audio output.	

## 6.12.6 Analogue Audio Commands

COMMAND
Description and Parameters
<b>set amplifier volume N1</b> ←
<p>Set the volume level of the amplified audio output.</p> <p>Available values for <b>N1</b>:</p> <p>0 ~ 80 [Volume in 0.5dB steps]</p> <p>UP [Increase volume 1 step]</p> <p>DOWN [Decrease volume 1 step]</p>
<b>get amplifier volume</b> ←
Show the current volume level of the amplified audio output.
<b>set amplifier left enhance N1</b> ←
<p>Increase the amplified audio output's left channel's volume level.</p> <p><b>N1</b> = 0 ~ 80 [Volume increase in 0.5dB steps]</p>
<b>get amplifier left enhance</b> ←
Show the current left channel volume enhancement amount.
<b>set amplifier right enhance N1</b> ←
<p>Increase the amplified audio output's right channel's volume level.</p> <p><b>N1</b> = 0 ~ 40 [Volume increase in 0.5dB steps]</p>
<b>get amplifier right enhance</b> ←
Show the current right channel volume enhancement amount.
<b>set analog audio lineout mute N1</b> ←
<p>Enable or disable muting the analogue audio line out.</p> <p>Available values for <b>N1</b>:</p> <p>ON [Muted]</p> <p>OFF [Unmuted]</p>
<b>get analog audio lineout mute</b> ←
Show the current mute state of the analogue audio line out.

### 6.12.6 Analogue Audio Commands

COMMAND
<b>Description and Parameters</b>
<b>set analog audio position fix N1 ↵</b>
Define the location of the amplified analogue speakers to restrict audio control to within the specified Zone.  Available values for <b>N1</b> : A [Restrict speaker control to Zone A] B [Restrict speaker control to Zone B] OFF [No control location restriction]
<b>get analog audio position fix ↵</b>
Show the current analogue audio position fix setting.
<b>set amplifier eq N1 gain N2 ↵</b>
Set the audio equaliser level at the specified frequency band for the amplified audio output.  Available values for <b>N1</b> : 64 [64Hz band] 125 [125Hz band] 250 [250Hz band] 500 [500Hz band] 1000 [1kHz band] 2000 [2kHz band] 4000 [4kHz band] 8000 [8kHz band] <b>N2 = -10 ~ 10</b> [Gain in dB]

### 6.12.6 Analogue Audio Commands

COMMAND	
Description and Parameters	
<b>get amplifier N1 eq gain</b> ←	
Show the current audio equaliser level at the specified frequency band for the amplified audio output.	
Available values for <b>N1</b> :	
64	[64Hz band]
125	[125Hz band]
250	[250Hz band]
500	[500Hz band]
1000	[1kHz band]
2000	[2kHz band]
4000	[4kHz band]
8000	[8kHz band]



### 6.12.7 Ethernet Commands

COMMAND	
Description and Parameters	
<b>set ip mode N1</b> ↵	
Set the IP address assignment mode.	
Available values for <b>N1</b> :	
STATIC	[Static IP Mode]
DHCP	[DHCP Mode]
<b>get ip mode</b> ↵	
Show the current IP address assignment mode.	
<b>set ip addr N1</b> ↵	
Set the unit's static IP address.	
<b>N1</b> = X.X.X.X	[X = 0 ~ 255, IP address]
<b>get ip addr</b> ↵	
Show the unit's current IP address.	
<b>set netmask</b> ↵	
Set the unit's static netmask.	
<b>N1</b> = X.X.X.X	[X = 0 ~ 255, netmask]
<b>get netmask</b> ↵	
Show the unit's current netmask.	
<b>set gateway N1</b> ↵	
Set the unit's static gateway address.	
<b>N1</b> = X.X.X.X	[X = 0 ~ 255, gateway address]
<b>get gateway</b> ↵	
Show the unit's current gateway address.	
<b>set http port N1</b> ↵	
Set the unit's WebGUI access port.	
<b>N1</b> = 0 ~ 65535	[Network port]

### 6.12.7 Ethernet Commands

COMMAND
Description and Parameters
<b>get http port</b> ←
Show the unit's current WebGUI access port.
<b>set telnet port N1</b> ←
Set the unit's Telnet access port.
<b>N1</b> = 0 ~ 65535            [Network port]
<b>get telnet port</b> ←
Show the unit's current Telnet access port.
<b>get ipconfig</b> ←
Show the unit's current IP configuration information.
<b>set webgui login timeout N1</b> ←
Set the WebGUI inactivity timeout value.
Available values for <b>N1</b> :
0                                    [No timeout]
1 ~ 65535                        [Timeout in minutes]
<b>get webgui login timeout</b> ←
Show the current WebGUI inactivity timeout value.
<b>set ethernet default</b> ←
Reset the Ethernet settings to their factory defaults.

## 6.12.8 IR Control System Commands

### COMMAND

#### Description and Parameters

#### set ir N1 remote control name N2 ↵

Set a name for the IR remote control used to control the device connected to the specified input/output port.

Available values for **N1**:

1 ~ 4	[HDMI Input device]
A ~ B	[HDBaseT Output device]
C	[HDMI Output device]
<b>N2</b> = {Name}	[32 characters max]

#### get ir N1 remote control name ↵

Show the current name for the IR remote control used to control the device connected to the specified input/output port.

Available values for **N1**:

1 ~ 4	[HDMI Input device]
A ~ B	[HDBaseT Output device]
C	[HDMI Output device]

### 6.12.8 IR Control System Commands

COMMAND
Description and Parameters
<p><b>set ir N1 learn to N2 func N3</b> ←</p> <p>Set the IR receiver location to use when learning IR command <b>N3</b> assigned to the device connected to input/output port <b>N2</b> and activate the learning function.</p> <p>Available values for <b>N1</b>:</p> <p>A [Zone A IR receiver]            B [Zone B IR receiver]            C [Front IR window]</p> <p>Available values for <b>N2</b>:</p> <p>1 ~ 4 [HDMI Input device]            A ~ B [HDBaseT Output device]            C [HDMI Output device]</p> <p><b>N3</b> = 1 ~ 60 [IR button function number]</p>
<p><b>set ir N1 emit with func N2</b> ←</p> <p>Transmit the IR code stored in button <b>N2</b> for the device located at IR blaster location <b>N1</b>.</p> <p>Available values for <b>N1</b>:</p> <p>1 ~ 4 [IR output 1 ~ 4]            A ~ B [HDBaseT Receiver A ~ B]            C [IR output 5]</p> <p><b>N2</b> = 1 ~ 60 [IR button function number]</p>
<p><b>set ir N1 delete func N2</b> ←</p> <p>Delete the IR code stored in button <b>N2</b> for device <b>N1</b>.</p> <p>Available values for <b>N1</b>:</p> <p>1 ~ 4 [HDMI Input device]            A ~ B [HDBaseT Output device]            C [HDMI Output device]</p> <p><b>N2</b> = 1 ~ 60 [IR button function number]</p>

### 6.12.8 IR Control System Commands

COMMAND										
Description and Parameters										
<p><b>set ir N1 advance mode N2</b> ←</p> <p>Enable or disable the “Advance mode” for the specified device’s remote control.</p> <p>Available values for <b>N1</b>:</p> <table style="width: 100%; border: none;"> <tr> <td style="width: 100px;">1 ~ 4</td> <td>[HDMI Input device]</td> </tr> <tr> <td>A ~ B</td> <td>[HDBaseT Output device]</td> </tr> <tr> <td>C</td> <td>[HDMI Output device]</td> </tr> </table> <p>Available values for <b>N2</b>:</p> <table style="width: 100%; border: none;"> <tr> <td style="width: 100px;">ON</td> <td>[Advance mode on]</td> </tr> <tr> <td>OFF</td> <td>[Advance mode off]</td> </tr> </table>	1 ~ 4	[HDMI Input device]	A ~ B	[HDBaseT Output device]	C	[HDMI Output device]	ON	[Advance mode on]	OFF	[Advance mode off]
1 ~ 4	[HDMI Input device]									
A ~ B	[HDBaseT Output device]									
C	[HDMI Output device]									
ON	[Advance mode on]									
OFF	[Advance mode off]									
<p><b>get ir N1 advance mode</b> ←</p> <p>Show the current “Advance mode” setting for the specified device’s remote control.</p> <p>Available values for <b>N1</b>:</p> <table style="width: 100%; border: none;"> <tr> <td style="width: 100px;">1 ~ 4</td> <td>[HDMI Input device]</td> </tr> <tr> <td>A ~ B</td> <td>[HDBaseT Output device]</td> </tr> <tr> <td>C</td> <td>[HDMI Output device]</td> </tr> </table>	1 ~ 4	[HDMI Input device]	A ~ B	[HDBaseT Output device]	C	[HDMI Output device]				
1 ~ 4	[HDMI Input device]									
A ~ B	[HDBaseT Output device]									
C	[HDMI Output device]									
<p><b>set ir N1 extension mode N2</b> ←</p> <p>Enable or disable the “Extension mode” for the specified device’s remote control.</p> <p>Available values for <b>N1</b>:</p> <table style="width: 100%; border: none;"> <tr> <td style="width: 100px;">1 ~ 4</td> <td>[HDMI Input device]</td> </tr> <tr> <td>A ~ B</td> <td>[HDBaseT Output device]</td> </tr> <tr> <td>C</td> <td>[HDMI Output device]</td> </tr> </table> <p>Available values for <b>N2</b>:</p> <table style="width: 100%; border: none;"> <tr> <td style="width: 100px;">ON</td> <td>[Extension mode on]</td> </tr> <tr> <td>OFF</td> <td>[Extension mode off]</td> </tr> </table>	1 ~ 4	[HDMI Input device]	A ~ B	[HDBaseT Output device]	C	[HDMI Output device]	ON	[Extension mode on]	OFF	[Extension mode off]
1 ~ 4	[HDMI Input device]									
A ~ B	[HDBaseT Output device]									
C	[HDMI Output device]									
ON	[Extension mode on]									
OFF	[Extension mode off]									

### 6.12.8 IR Control System Commands

COMMAND												
<p><b>Description and Parameters</b></p>												
<p><b>get ir N1 extension mode</b> ←</p> <p>Show the current “Extension mode” setting for the specified device’s remote control.</p> <p>Available values for <b>N1</b>:</p> <table> <tr> <td>1 ~ 4</td> <td>[HDMI Input device]</td> </tr> <tr> <td>A ~ B</td> <td>[HDBaseT Output device]</td> </tr> <tr> <td>C</td> <td>[HDMI Output device]</td> </tr> </table>	1 ~ 4	[HDMI Input device]	A ~ B	[HDBaseT Output device]	C	[HDMI Output device]						
1 ~ 4	[HDMI Input device]											
A ~ B	[HDBaseT Output device]											
C	[HDMI Output device]											
<p><b>set ir N1 default mode N2</b> ←</p> <p>Set the default mode screen to show in the app for the specified device’s remote control.</p> <p>Available values for <b>N1</b>:</p> <table> <tr> <td>1 ~ 4</td> <td>[HDMI Input device]</td> </tr> <tr> <td>A ~ B</td> <td>[HDBaseT Output device]</td> </tr> <tr> <td>C</td> <td>[HDMI Output device]</td> </tr> </table> <p>Available values for <b>N2</b>:</p> <table> <tr> <td>1</td> <td>[Normal mode]</td> </tr> <tr> <td>2</td> <td>[Advance mode]</td> </tr> <tr> <td>3</td> <td>[Extension mode]</td> </tr> </table>	1 ~ 4	[HDMI Input device]	A ~ B	[HDBaseT Output device]	C	[HDMI Output device]	1	[Normal mode]	2	[Advance mode]	3	[Extension mode]
1 ~ 4	[HDMI Input device]											
A ~ B	[HDBaseT Output device]											
C	[HDMI Output device]											
1	[Normal mode]											
2	[Advance mode]											
3	[Extension mode]											
<p><b>get ir N1 default mode</b> ←</p> <p>Show the current default mode screen shown in the app for the specified device’s remote control.</p> <p>Available values for <b>N1</b>:</p> <table> <tr> <td>1 ~ 4</td> <td>[HDMI Input device]</td> </tr> <tr> <td>A ~ B</td> <td>[HDBaseT Output device]</td> </tr> <tr> <td>C</td> <td>[HDMI Output device]</td> </tr> </table>	1 ~ 4	[HDMI Input device]	A ~ B	[HDBaseT Output device]	C	[HDMI Output device]						
1 ~ 4	[HDMI Input device]											
A ~ B	[HDBaseT Output device]											
C	[HDMI Output device]											

## 6.12.8 IR Control System Commands

COMMAND
Description and Parameters
<p><b>set ir N1 toggle mode N2 ↵</b></p> <p>Enable or disable the ability of the “Play/Pause” function button of the specified device’s remote control to toggle between separate commands for “Play” and “Pause”.</p> <p>Available values for <b>N1</b>:</p> <p>1 ~ 4                           [HDMI Input device]  A ~ B                           [HDBaseT Output device]  C                                 [HDMI Output device]</p> <p>Available values for <b>N2</b>:</p> <p>ON                               [Play/Pause uses two commands]  OFF                              [Play/Pause uses a single command]</p>
<p><b>get ir N1 toggle mode ↵</b></p> <p>Show the current “Play/Pause” toggle mode for the specified device’s remote control.</p> <p>Available values for <b>N1</b>:</p> <p>1 ~ 4                           [HDMI Input device]  A ~ B                           [HDBaseT Output device]  C                                 [HDMI Output device]</p>
<p><b>set ir N1 extension N2 name N3 ↵</b></p> <p>Set a name for the specified device’s Extension mode remote control function button <b>N2</b>.</p> <p>Available values for <b>N1</b>:</p> <p>1 ~ 4                           [HDMI Input device]  A ~ B                           [HDBaseT Output device]  C                                 [HDMI Output device]</p> <p><b>N2</b> = 32, 34, 39 ~ 60       [IR button function number]  <b>N3</b> = {Name}                 [32 characters max]</p>

### 6.12.8 IR Control System Commands

COMMAND						
Description and Parameters						
<p><b>get ir N1 extension N2 name</b> ←</p> <p>Show the current name for the specified device's Extension mode remote control function button <b>N2</b>.</p> <p>Available values for <b>N1</b>:</p> <table style="width: 100%; border: none;"> <tr> <td style="width: 15%;">1 ~ 4</td> <td>[HDMI Input device]</td> </tr> <tr> <td>A ~ B</td> <td>[HDBaseT Output device]</td> </tr> <tr> <td>C</td> <td>[HDMI Output device]</td> </tr> </table> <p><b>N2</b> = 32, 34, 39 ~ 60      [IR button function number]</p>	1 ~ 4	[HDMI Input device]	A ~ B	[HDBaseT Output device]	C	[HDMI Output device]
1 ~ 4	[HDMI Input device]					
A ~ B	[HDBaseT Output device]					
C	[HDMI Output device]					
<p><b>set ir bypass N1</b> ←</p> <p>Enable or disable the IR bypass and auto-IR routing mode.</p> <p>Available values for <b>N1</b>:</p> <table style="width: 100%; border: none;"> <tr> <td style="width: 15%;">ON</td> <td>[Bypass enabled]</td> </tr> <tr> <td>OFF</td> <td>[Bypass disabled]</td> </tr> </table> <p><i>Note: When IR Bypass is enabled, unit-generated IR commands will be delayed by 100ms to avoid conflict with the bypassed IR command.</i></p>	ON	[Bypass enabled]	OFF	[Bypass disabled]		
ON	[Bypass enabled]					
OFF	[Bypass disabled]					
<p><b>get ir bypass</b> ←</p> <p>Show the current state of the IR bypass mode setting.</p>						
<p><b>set ir channel N1</b> ←</p> <p>Set the channel for the IR inputs to use.</p> <p><b>N1</b> = 0 ~ 3      [IR channel]</p> <p><i>Note: The IR channel of the unit and the dedicated IR remote control must match in order for the unit to be controlled.</i></p>						



### 6.12.8 IR Control System Commands

COMMAND	
Description and Parameters	
<b>get ir channel</b> ↵	
	Show the current channel used by the IR inputs.
<b>set control system default</b> ↵	
	Reset the IR control system settings to their factory defaults and clear all stored IR commands.

### 6.12.9 OSD Info Commands

COMMAND																
Description and Parameters																
<p><b>set osd font size N1 ↵</b></p> <p>Set the font size for the OSD banner.</p> <p>Available values for <b>N1</b>:</p> <table> <tr> <td>1</td> <td>[Normal]</td> </tr> <tr> <td>2</td> <td>[Large]</td> </tr> </table>	1	[Normal]	2	[Large]												
1	[Normal]															
2	[Large]															
<p><b>get osd font size ↵</b></p> <p>Show the current font size for the OSD banner.</p>																
<p><b>set osd font color N1 ↵</b></p> <p>Set the colour of the font used by the OSD banner.</p> <p>Available values for <b>N1</b>:</p> <table> <tr> <td>1</td> <td>[Black]</td> </tr> <tr> <td>2</td> <td>[White]</td> </tr> <tr> <td>3</td> <td>[Red]</td> </tr> <tr> <td>4</td> <td>[Green]</td> </tr> <tr> <td>5</td> <td>[Blue]</td> </tr> <tr> <td>6</td> <td>[Yellow]</td> </tr> <tr> <td>7</td> <td>[Cyan]</td> </tr> <tr> <td>8</td> <td>[Magenta]</td> </tr> </table>	1	[Black]	2	[White]	3	[Red]	4	[Green]	5	[Blue]	6	[Yellow]	7	[Cyan]	8	[Magenta]
1	[Black]															
2	[White]															
3	[Red]															
4	[Green]															
5	[Blue]															
6	[Yellow]															
7	[Cyan]															
8	[Magenta]															
<p><b>get osd font color ↵</b></p> <p>Show the current colour of the font used by the OSD banner.</p>																

### 6.12.9 OSD Info Commands

COMMAND	
Description and Parameters	
<b>set osd background color N1</b> ←	
Set the colour of the background of the OSD banner. Available values for <b>N1</b> : 1 [Black] 2 [White] 3 [Red] 4 [Green] 5 [Blue] 6 [Yellow] 7 [Cyan] 8 [Magenta]	
<b>get osd background color</b> ←	
Show the current colour of the background of the OSD banner.	
<b>set osd freerun color N1</b> ←	
Set the freerun colour to use when the current input does not have a valid source. Available values for <b>N1</b> : 0 [Disable freerun] 1 [Red] 2 [Green] 3 [Blue] 4 [Black] 5 [Colour bars]	
<b>get osd freerun color</b> ←	
Show the current freerun colour.	

### 6.12.9 OSD Info Commands

COMMAND				
Description and Parameters				
<p><b>set osd in notify N1</b> ←</p> <p>Set the length of time to display the current input's name on the OSD after switching inputs.</p> <p>Available values for <b>N1</b>:</p> <table style="width: 100%; border: none;"> <tr> <td style="width: 50%;">0</td> <td>[OSD notification disabled]</td> </tr> <tr> <td>1 ~ 255</td> <td>[Timeout in seconds]</td> </tr> </table>	0	[OSD notification disabled]	1 ~ 255	[Timeout in seconds]
0	[OSD notification disabled]			
1 ~ 255	[Timeout in seconds]			
<p><b>get osd in notify</b> ←</p> <p>Show the current OSD input notify setting.</p>				
<p><b>set osd audio notify N1</b> ←</p> <p>Set the length of time to display the current audio status on the OSD after switching audio sources.</p> <p>Available values for <b>N1</b>:</p> <table style="width: 100%; border: none;"> <tr> <td style="width: 50%;">0</td> <td>[OSD notification disabled]</td> </tr> <tr> <td>1 ~ 255</td> <td>[Timeout in seconds]</td> </tr> </table>	0	[OSD notification disabled]	1 ~ 255	[Timeout in seconds]
0	[OSD notification disabled]			
1 ~ 255	[Timeout in seconds]			
<p><b>get osd audio notify</b> ←</p> <p>Show the current OSD audio notify setting.</p>				
<p><b>set osd ir notify N1</b> ←</p> <p>Set the length of time to display the IR command name on the OSD after an IR command is received.</p> <p>Available values for <b>N1</b>:</p> <table style="width: 100%; border: none;"> <tr> <td style="width: 50%;">0</td> <td>[OSD notification disabled]</td> </tr> <tr> <td>1 ~ 255</td> <td>[Timeout in seconds]</td> </tr> </table>	0	[OSD notification disabled]	1 ~ 255	[Timeout in seconds]
0	[OSD notification disabled]			
1 ~ 255	[Timeout in seconds]			
<p><b>get osd ir notify</b> ←</p> <p>Show the current OSD IR notify setting.</p>				

### 6.12.9 OSD Info Commands

COMMAND	
Description and Parameters	
<b>set osd app notify N1 ↵</b>	
Set the length of time to display the command name on the OSD after a command is activated via the mobile device app.	
Available values for <b>N1</b> :	
0	[OSD notification disabled]
1 ~ 255	[Timeout in seconds]
<b>get osd app notify ↵</b>	
Show the current OSD app notify setting.	
<b>set osd default ↵</b>	
Reset the OSD settings to their factory defaults.	

*Note: Commands will not be executed unless followed by a carriage return. Commands are not case-sensitive.*

# 7. CONNECTION DIAGRAM

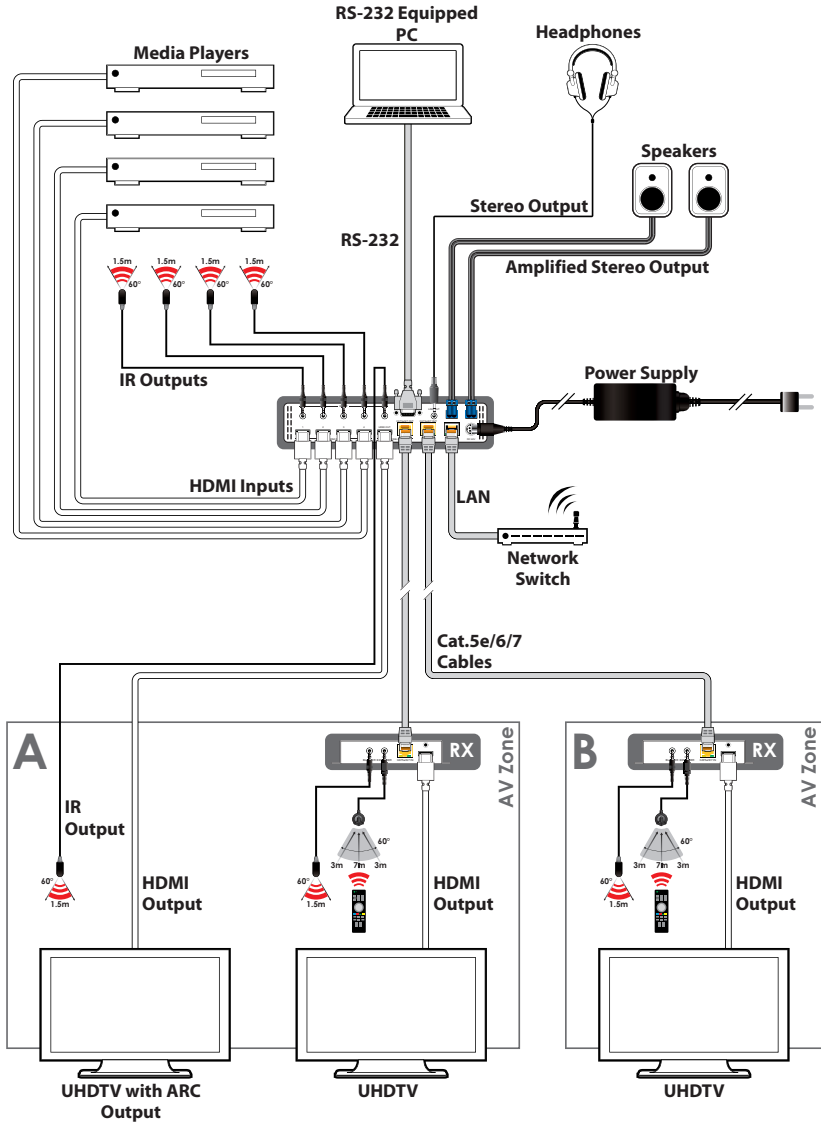

## 8. SPECIFICATIONS

### 8.1 Technical Specifications -Matrix

<b>HDMI Bandwidth</b>	600MHz/18Gbps
<b>HDBaseT Bandwidth</b>	340MHz/10.2Gbps
<b>Input Ports</b>	4×HDMI
<b>Output Ports</b>	1×HDMI 2×HDBaseT (RJ-45) 1×Analogue Stereo (2×Terminal Block) 1×Analogue Stereo (3.5mm)
<b>Pass-through Ports</b>	5×IR Blaster (3.5mm)
<b>Control Ports</b>	1×RS-232 (DE-9) 1×IP Control (RJ-45)
<b>Service Port</b>	1×USB (Type-A)
<b>IR Frequency</b>	30 – 50kHz (30–60kHz under ideal conditions)
<b>Baud Rate</b>	19200
<b>Power Supply</b>	24V/2.7A DC (US/EU standards, CE/FCC/UL certified)
<b>ESD Protection</b>	Human Body Model: ±8kV (Air Discharge) ±4kV (Contact Discharge)
<b>Dimensions</b>	219mm×43mm×156mm (W×H×D) [Case Only] 219mm×54mm×163.5mm (W×H×D) [All Inclusive]
<b>Weight</b>	1,258g
<b>Chassis Material</b>	Metal (Steel)
<b>Chassis Colour</b>	Black
<b>Operating Temperature</b>	0°C – 40°C/32°F – 104°F
<b>Storage Temperature</b>	–20°C – 60°C/-4°F – 140°F
<b>Relative Humidity</b>	20 – 90% RH (Non-condensing)
<b>Power Consumption</b>	46.64W

## 8.2 Technical Specifications - Receiver

<b>HDMI Bandwidth</b>	600MHz/18Gbps
<b>HDBaseT Bandwidth</b>	340MHz/10.2Gbps
<b>Input Port</b>	1×HDBaseT (RJ-45)
<b>Output Ports</b>	1×HDMI
<b>Pass-through Ports</b>	1×IR Blaster (3.5mm) 1×IR Extender (3.5mm) 1×RS-232 (DE-9)
<b>IR Frequency</b>	30 – 50kHz (30 – 60kHz under ideal conditions)
<b>Baud Rate</b>	Up to 115200
<b>Power Supply</b>	48V PoH
<b>ESD Protection</b>	Human Body Model: ±8kV (Air Discharge) ±4kV (Contact Discharge)
<b>Dimensions</b>	128mm×25mm×108mm (W×H×D) [Case Only] 128mm×25mm×117mm (W×H×D) [All Inclusive]
<b>Weight</b>	386g
<b>Chassis Material</b>	Metal (Steel)
<b>Silkscreen Colour</b>	Black
<b>Operating Temperature</b>	0°C – 40°C/32°F – 104°F
<b>Storage Temperature</b>	–20°C – 60°C/–4°F – 140°F
<b>Relative Humidity</b>	20 – 90% RH (Non-condensing)
<b>Power Consumption</b>	9.8W



## 8.2 Video Specifications

Supported Resolutions (Hz)	Input		Output	
	HDMI	HDBT	HDMI	HDBT
<b>720x400p@70/85</b>	✓	✓	✓	✓
<b>640x480p@60/72/75/85</b>	✓	✓	✓	✓
<b>720x480i@60</b>	✓	✓	✓	✓
<b>720x480p@60</b>	✓	✓	✓	✓
<b>720x576i@50</b>	✓	✓	✓	✓
<b>720x576p@50</b>	✓	✓	✓	✓
<b>800x600p@56/60/72/75/85</b>	✓	✓	✓	✓
<b>848x480p@60</b>	✓	✓	✓	✓
<b>1024x768p@60/70/75/85</b>	✓	✓	✓	✓
<b>1152x864p@75</b>	✓	✓	✓	✓
<b>1280x720p@50/60</b>	✓	✓	✓	✓
<b>1280x768p@60RB/60/75/85</b>	✓	✓	✓	✓
<b>1280x800p@60RB/60/75/85</b>	✓	✓	✓	✓
<b>1280x960p@60/85</b>	✓	✓	✓	✓
<b>1280x1024p@60/75/85</b>	✓	✓	✓	✓
<b>1360x768p@60</b>	✓	✓	✓	✓
<b>1366x768p@60RB/60</b>	✓	✓	✓	✓
<b>1400x1050p@60RB/60</b>	✓	✓	✓	✓
<b>1440x900p@60RB/60/75</b>	✓	✓	✓	✓
<b>1600x900p@60RB</b>	✓	✓	✓	✓
<b>1600x1200p@60</b>	✓	✓	✓	✓
<b>1680x1050p@60RB/60</b>	✓	✓	✓	✓
<b>1920x1080i@50/60</b>	✓	✓	✓	✓
<b>1920x1080p@24/25/30</b>	✓	✓	✓	✓

Supported Resolutions (Hz)	Input		Output	
	HDMI	HDBT	HDMI	HDBT
<b>1920×1080p@50/60</b>	✓	✓	✓	✓
<b>1920×1200p@60RB</b>	✓	✓	✓	✓
<b>2560×1440p@60RB</b>	×	×	×	×
<b>2560×1600p@60RB</b>	×	×	×	×
<b>2048×1080p@24/25/30</b>	✓	✓	✓	✓
<b>2048×1080p@50/60</b>	✓	✓	✓	✓
<b>3840×2160p@24/25/30</b>	✓	✓	✓	✓
<b>3840×2160p@50/60 (4:2:0)</b>	✓	✓	✓	✓
<b>3840×2160p@24/25/30, HDR10</b>	✓	AVLC	✓	AVLC
<b>3840×2160p@50/60 (4:2:0), HDR10</b>	✓	AVLC	✓	AVLC
<b>3840×2160p@50/60</b>	✓	AVLC	✓	AVLC
<b>4096×2160p@24/25/30</b>	✓	✓	✓	✓
<b>4096×2160p@50/60 (4:2:0)</b>	✓	✓	✓	✓
<b>4096×2160p@24/25/30, HDR10</b>	×	×	×	×
<b>4096×2160p@50/60 (4:2:0), HDR10</b>	×	×	×	×
<b>4096×2160p@50/60</b>	×	×	×	×

## 8.3 Audio Specifications

### 8.3.1 Digital Audio

HDMI & HDBaseT Input/Output	
LPCM	
<b>Max Channels</b>	8 Channels
<b>Sampling Rate (kHz)</b>	32, 44.1, 48, 88.2, 96, 176.4, 192
Bitstream	
<b>Supported Formats</b>	Standard & High-Definition

### 8.3.2 Analogue Audio

Analogue Output (Amplified Output)	
<b>Output Power</b>	20W + 20W
<b>THD+N</b>	< -66dB@0dBFS 1kHz (A-wt)
<b>SNR</b>	> 100dB@0dBFS
<b>Frequency Response</b>	< ±3dB@20Hz~20kHz
<b>Crosstalk</b>	< -80dB@10kHz
<b>Impedance</b>	4 – 16Ω
<b>Type</b>	Balanced

Analogue Output (Line Output)	
<b>Max Audio Level</b>	2Vrms
<b>THD+N</b>	< -84dB@0dBFS 1kHz (A-wt)
<b>SNR</b>	> 104dB@0dBFS
<b>Frequency Response</b>	< ±0.5dB@20Hz~20kHz
<b>Crosstalk</b>	< -76dB@10kHz
<b>Impedance</b>	500Ω
<b>Type</b>	Unbalanced

## 8.5 HDBaseT Features

HDBaseT Feature Set	Transmitter
<b>Video &amp; Audio</b>	Supported
<b>LAN Pass-through</b>	Supported
<b>Send power to Receiver</b>	Supported
<b>Accept power from Receiver</b>	Unsupported
<b>IR Pass-through</b>	Supported
<b>RS-232 Pass-through</b>	Supported

HDBaseT Feature Set	Receiver
<b>Video &amp; Audio</b>	Supported
<b>LAN Pass-through</b>	Supported
<b>Send power to Transmitter</b>	Unsupported
<b>Accept power from Transmitter</b>	Supported
<b>IR Pass-through</b>	Supported
<b>RS-232 Pass-through</b>	Supported

## 9. ACRONYMS

ACRONYM	COMPLETE TERM
<b>ARC</b>	Audio Return Channel
<b>ASCII</b>	American Standard Code for Information
<b>AV</b>	Audio/Video
<b>AVLC</b>	Adaptive Visually Lossless Compression
<b>Cat.5e</b>	Enhanced Category 5 cable
<b>Cat.6</b>	Category 6 cable
<b>Cat.6a</b>	Augmented Category 6 cable
<b>Cat.7</b>	Category 7 cable
<b>CEC</b>	Consumer Electronics Control
<b>CLI</b>	Command-Line Interface
<b>DAC</b>	Digital-to-Analogue Converter
<b>DHCP</b>	Dynamic Host Configuration Protocol
<b>DVI</b>	Digital Visual Interface
<b>EDID</b>	Extended Display Identification Data
<b>GUI</b>	Graphical User Interface
<b>HD</b>	High-Definition
<b>HDBT</b>	HDBaseT
<b>HDCP</b>	High-bandwidth Digital Content Protection
<b>HDMI</b>	High-Definition Multimedia Interface
<b>HDR</b>	High Dynamic Range
<b>HDTV</b>	High-Definition Television
<b>IP</b>	Internet Protocol
<b>IR</b>	Infrared
<b>LAN</b>	Local Area Network
<b>LED</b>	Light-Emitting Diode

ACRONYM	COMPLETE TERM
<b>LPCM</b>	Linear Pulse-Code Modulation
<b>MAC</b>	Media Access Control
<b>OSD</b>	On-Screen Display
<b>PD</b>	Powered Device
<b>PoH</b>	Power over HDBaseT
<b>PSE</b>	Power Sourcing Equipment
<b>SNR</b>	Signal-to-Noise Ratio
<b>TCP</b>	Transmission Control Protocol
<b>THD+N</b>	Total Harmonic Distortion plus Noise
<b>UHD</b>	Ultra-High-Definition
<b>UHD+</b>	Ultra-High-Definition Plus
<b>UHDTV</b>	Ultra-High-Definition Television
<b>USB</b>	Universal Serial Bus
<b>VGA</b>	Video Graphics Array
<b>WUXGA (RB)</b>	Widescreen Ultra Extended Graphics Array (Reduced Blanking)
<b>XGA</b>	Extended Graphics Array





---

CYP (UK) Ltd., Unit 7, Shepperton Business Park, Govett Avenue, Shepperton,  
Middlesex, TW17 8BA

Tel: +44 (0) 20 3137 9180 | Fax: +44 (0) 20 3137 6279

Email: [sales@cypeurope.com](mailto:sales@cypeurope.com)

[www.cypeurope.com](http://www.cypeurope.com)

v1.00